



**DAF Trucks Polska Sp. z o.o.**



2026-03-23 | D0839778

**XB 260 FA 4X2 Podwozie pod zabudowę, 12t PMC26PL20 XB 260 FA  
Curtain Sider Body Domestic 18P \_ 20**

**XB 260 FA 4X2 Podwozie pod zabudowę, 12t PMC26PL20 XB 260 FA  
Curtain Sider Body Domestic 18P \_ 20**

---

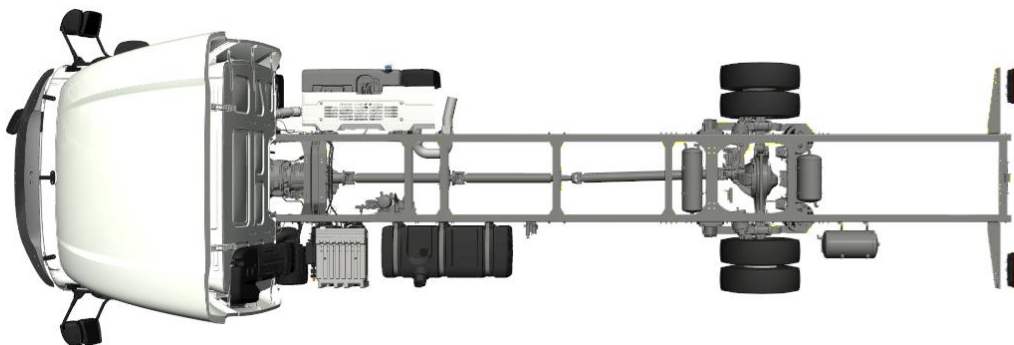
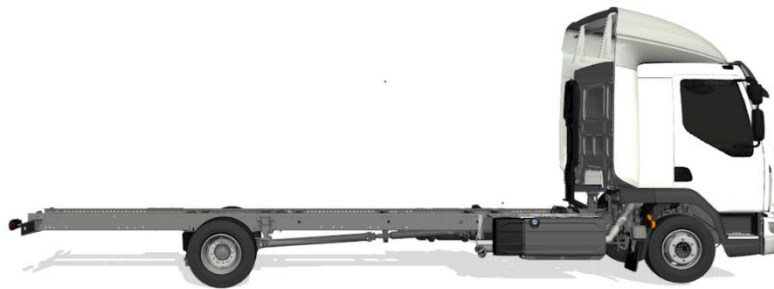
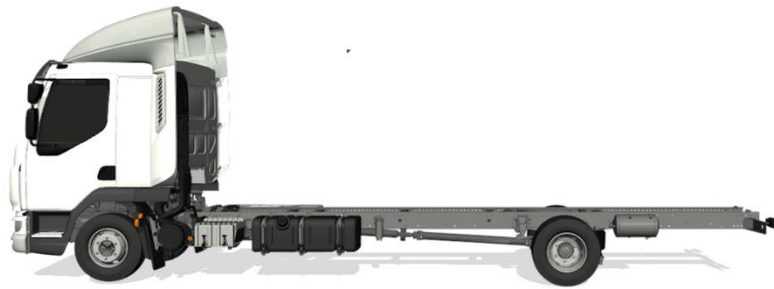

## Vehicle Summary XB 260 FA 4X2 Podwozie pod zabudowę, 12t PMC26PL20 XB 260 FA Curtain Sider Body Domestic 18P \_ 20

<b>Market packages</b>	No market package
<b>Application packages 1</b>	No application option
<b>Cab version</b>	Sleeper Cab
<b>Roof air deflector</b>	Adjustable roof air deflector high (set)
<b>Cab colour</b>	E1980WHTE
<b>Connected Services</b>	PACCAR Connect
<b>Audio and infotainment</b>	FM/DAB/DAB+ radio with speakers incl. phone con.
<b>Front axle</b>	Front: 4.50 t, parabolic, 45N
<b>Rear axle</b>	Rear: 8.50 t, air suspension, SR8.14
<b>Supplier tyres</b>	Goodyear
<b>Tyres fr1 or fr axles</b>	F1,245/70R17.5GO KMAXS2 136/134 M Steering CCA 3P
<b>Tyres driven rear axle(s)</b>	R1,245/70R17.5GO KMAXD2 136/134 M Traction CCA 3P
<b>Spare tyre</b>	SP,245/70R17.5GO KMAXD2 136/134 M Traction CCA 3P
<b>Engine</b>	Engine PX-7 , 189 kW/257 hp. Cab Badge: 260
<b>Exhaust emission</b>	Exhaust emission Euro 6
<b>Gearbox execution</b>	Automatic gearbox PowerLine, 8-speed
<b>Rear axle ratio</b>	Rear axle ratio 3.73
<b>Wheelbase / rear overhang</b>	Wheelbase 5.40 m / rear overhang 2.43 m
<b>Chassis component layout</b>	Standard component location
<b>Fuel tank</b>	Plastic fuel tank 185 l
<b>Tank for AdBlue® position and content</b>	Tank for AdBlue® 55 l, right-hand side chassis
<b>Type plate related drawbar or solo application</b>	Type plate related solo application, no trailer
<b>Body type</b>	No ex works body type
<b>Chassis weight related gross vehicle mass GVM</b>	Chassis weight related technical GVM max 11990 kg
<b>Vehicle warranty</b>	Warranty Plus-Vehicle-3 years-200K

## Detailed Specification XB 260 FA 4X2 Podwozie pod zabudowę, 12t PMC26PL20 XB 260 FA Curtain Sider Body Domestic 18P \_ 20

---

### CAB EXTERIOR

- **Sleeper Cab with steel bumper, tinted glass and electric window openers. Main mirrors and wide angle mirrors electrically heated. Cab width 2130 mm.**
- **Reinforced mechanical cab suspension.**
- **Translucent external sun visor above the windscreen, colour green.**
- **Bi-reflector halogen head lights with impact-resistant Lexan lens.**
- Head light beam for right-hand traffic.
- Daytime running lights.
- **Bumper mounted fog lights.**
- Green tinted glass.
- Main mirror and wide angle mirror at driver's side and co-driver's side. Kerb view mirror at co-driver's side.
- Electrical adjustment of the main mirrors.
- Mirror brackets for body width 2.50 - 2.60 m.
- Front view mirror to comply with EC directive 2003/97/EC for frontal field of view.
- Camera at the rear of the vehicle for rear view. Camera images will be shown on a dedicated display.
- Central door lock system with exterior light check function. Includes 2 remote control units and 2 transponder keys.

### AERODYNAMICS

- **Adjustable roof air deflector shaped for aerodynamic streamline between the cab and the body.**
- **Long side collars.**

### COLOURS

- Cab colour: E1980WHTE
- **Headlamp panel and bumper in cab colour.**
- Cab steps and wing Stone Grey.
- **Colour roof air deflector: Crystal white.**
- **Colour of side collars: Crystal white.**
- Chassis colour grey.

### CAB INTERIOR

- Left-hand drive.

- **Steering wheel, finished with leather in black colour.**
- **Steering column rake and height adjustment with pneumatically controlled lock.**
- **Luxury air suspended driver seat with adjustable damper and pneumatic lumbar support. Seat cushion heating. Integral head restraint. Three-point seat belt. Seat upholstery velour.**
- **Arm rest on the driver seat.**
- Fixed co-driver seat with integral head restraint and three-point seat belt. Seat upholstery velour with vinyl rear.
- **Adjustable arm rest at the inner side of the co-driver seat.**
- Seat belts black.
- **Sleeping compartment with lower bunk at engine-tunnel level. Storage facilities under the bunk: 3 storage boxes (total volume 65 litres) accessible with tilted bunk.**
- **Curtains along the windscreen and the side windows.**
- Manually controlled airco with air recirculation.
- **Air-to-air auxiliary cab heater, Webasto Air Top 2000. Heat output 0.9 - 2.0 kW.**
- **Roof hatch with manual control.**
- Electric window openers.
- Converter 24V to 12V, 15A, 180W.
- **ECAS remote control with illuminated buttons for various functions including four memory buttons for pre-set chassis heights.**

### COMMUNICATION AND DRIVING MANAGEMENT

- Universal FMS (Fleet Management System) connector with wiring, to read information as defined in the truck manufacturers' FMS standard.
- PACCAR Connect subscription. PACCAR Connect is an online fleet management system providing insight in relevant truck, driver, and location information.
- **Preparation for satellite communication equipment for the German Maut tax system, consisting of wiring to the installation positions of the on-board unit (OBU) and the digital short-range communication unit (DSRC).**
- **Digital (smart) tachograph VDO DTCO with Galileo Navigation Satellite System (GNSS) receiver, OS-NMA service declaration and dedicated short-range communications (DSRC) unit, compliant to EU Mobility package 1 as described in the EU tachograph regulations.**
- **Speed limiter setting for cruise control/accelerator pedal: 90 km/h.**
- DAF Infotainment System: FM/DAB/DAB+ radio integrated in the system as well as streaming functionalities via USB and Bluetooth. Audio information displayed on the digital instrument panel. Controls via right-hand spoke of the steering wheel. Option does not include a separate infotainment display. The Basic speaker system consists of three speakers: two bass speakers in the door panels (one in each door) and a full-range frequency speaker at the centre of the dashboard.
- Combi-antenna for AM/FM, GSM and GPS. GSM ranges 900 MHz, 1800 MHz and GPRS.
- ACC (Adaptive Cruise Control) with FCW (Forward Collision Warning) and AEBS-3 (AEBS: Advanced Emergency Braking System). With ACC a set distance to the traffic ahead can be maintained; safety systems FCW and AEBS assist in avoiding or mitigating the impact of an impending collision with various moving or

stationary objects in front of the vehicle, like other road users or crossing pedestrians, by alerting the driver and activating the brakes if necessary.

- Driver Performance Assistant (DPA). Interactive programme to support the driver in achieving the most cost effective driving style. The DPA information is shown on the 5 inch full colour TFT display in the instrument panel.

### SAFETY AND SECURITY

- Speed limit recognition informs the driver of the maximum permitted speed, using map-based information and traffic sign recognition via a camera at the front of the vehicle.
- DAF drowsiness & distraction detection assesses the driver's alertness through vehicle system analysis and warns the driver, when deemed necessary. Additionally, the system monitors drivers focus using visual data.
- Lane Departure Warning System to prevent inadvertent lane changes due to driver's fatigue or distraction and to form an effective driving aid in low visibility conditions.
- Electronic Vehicle Stability Control system (VSC) to enhance the active driving safety. Improved directional stability (understeer, oversteer jack-knifing) and additional roll-over safety.
- Acoustic reverse warning with override switch.
- Basic engine immobiliser with fuel injection inhibit and interruption of the starter motor circuit.
- **Manual main switch.**
- Drive-off Assist informs the driver of vulnerable road users in the front bumper area and, if applicable, warns the driver to prevent collision.
- Safety system that detects and informs the driver of a moving object near the co-driver's side of the vehicle. The system also supports the driver to prevent collisions with other road users when changing lane.
- Preparation for an alcohol interlock system.
- The vehicle supplied by DAF is compliant with UN Regulation R155 concerning cyber security management systems as well as UN Regulation R156 concerning software update management systems.

### SUSPENSION AND AXLES

- Front axle type 45N. Parabolic leaf suspension with shock absorbers and stabiliser. Max. load 4.5 tonnes.
- **Single reduction driven rear axle type SR8.14 with electronically controlled 2-bellow air suspension, including shock absorbers and stabiliser. Max. load 8.50 tonnes.**

### WHEELS AND TYRES

- Front axle(s): tyre size 245/70R17.5, wheel size 17.5 x 6.75.
- Driven rear axle(s): tyre size 245/70R17.5, wheel size 17.5 x 6.75.
- **Spare: tyre size 245/70R17.5, wheel size 17.5 x 6.75.**
- Supplier Goodyear.
- Tyre pressure monitoring.
- Steel disc wheels, silvergrey.
- Wheel protection rings with open centre section, colour silver-grey (RAL 9006).

- Front axle: tyre size 245/70R17.5, Goodyear type KMAXS2, load index 136/134, speed index M, application Steering - Regional. Tyre label: rolling resistance C - wet grip C - noise 71dB(A), Category A - 3PMSF - M+S - RFID.
- Driven rear axle: tyre size 245/70R17.5, Goodyear type KMAXD2, load index 136/134, speed index M, application Traction - Regional. Tyre label: rolling resistance C - wet grip C - noise 72dB(A), Category A - 3PMSF - M+S - RFID.
- **Spare wheel: tyre size 245/70R17.5, Goodyear type KMAXD2, load index 136/134, speed index M, application Traction - Regional. Tyre label: rolling resistance C - wet grip C - noise 72dB(A), Category A - 3PMSF - M+S - RFID.**

### DRIVELINE

- **Engine PX-7, 6 cylinder diesel engine, 6.7 litres. Output 189 kW (257 hp) at 2300 rpm. Max. torque 990 Nm at 1000-1700 rpm.**
- Exhaust emission Euro 6.
- Engine idle shutdown, after idling 5 minutes.
- Automatic gearbox PowerLine, 8-speeds.
- **Automatic overdrive gearbox PowerLine 8AP1000, ratio 4.89-0.64, 8 speeds.**
- Automated gearbox software optimised for standard transport applications. Gearbox control version: Full.
- **Rear axle ratio 3.73.**
- **Driven rear axle with a mechanical differential lock.**
- The ASR (anti-slip regulation) system prevents the driven wheels from slipping when accelerating at driving off and helps the vehicle to remain stable on critical road surfaces.

### BRAKE SYSTEM

- Exhaust brake. Function integration in the Electronic Brake System. If switched on with the steering wheel switch, the exhaust brake will operate on throttle release.
- Park brake control.

### CHASSIS

- **Wheelbase 5.40 m / rear overhang 2.43 m.**
- Side member height 210 mm, thickness 6.0 mm. No inner reinforcement.
- Standard location of chassis components.
- EAS unit and rearward exhaust discharge at the right-hand side of the chassis.
- Battery box at the left-hand side. No spare wheel carrier.
- **Plastic fuel tank 185 litres.**
- Fuel tank at the left-hand side of the chassis.
- **55 litres tank for AdBlue® positioned at the right-hand side of the chassis.**
- Filler cap without lock for tank for AdBlue®.
- Front underrun protection (FUP), according to EU directive 2000/40/EEC.
- Spray suppression in the mudguards, according to directive 91/226/EEC.

# DAF Trucks Polska Sp. z o.o.

- **Rear light brackets.**
- Rear light unit with bulbs.

## DRAWBAR AND TRAILER EQUIPMENT

- Type plate related solo application, without trailer.
- Closing cross member.

## BODIES AND PREPARATIONS FOR BODYING

- Body function connector A068 with engine speed control, remote engine start/stop and application speed limiter 1 and application speed limiter 2.
- Loose supply of a wiring loom with LED-type side marker lights.
- Standard body attachment hole pattern.

## 24V POWER SUPPLY

- **Alternator 100 A, batteries 2x 175 Ah.**

## GVM AND GCM

- Chassis weight related technical GVM max. 11990 kg.
- Driveline related technical GCM equal to GVM.

## APPLICATION CONDITIONS

- Application class 0 comprises Western-Europe excluding United Kingdom and Ireland.
- Standard noise level.
- **Cold climatic conditions, with temperatures below minus 12 degrees Celsius.**
- Maximum ambient temperature 38 degrees.
- **Moisture separator with 30 micron filter element and heated filter bowl. Status panel with drain warning on the dashboard.**
- **Air intake high behind cab.**

## SERVICE AND MAINTENANCE

- **Warranty Plus - Vehicle, takes care of 3 years complete vehicle as supplied by the OEM (excl. real wear parts) up to 200,000 km and 1st year breakdown.**
- ITS service.
- A number of parts used to manufacture a vehicle contain SVHCs (Substances of Very High Concern) as defined in the REACH legislation.

## VEHICLE DELIVERY

- Whole Vehicle Type Approval (WVTA) for European Union.
- Type plate EEC.

## DAF Trucks Polska Sp. z o.o.

- CoC document printed in Polish (PL) language.
- **Lifting jack.**
- Standard toolkit consisting of a 750 mm control lever, a 30/32 mm wheel nut wrench, a 30 mm box wrench, an approximately 800 mm long torque pipe, a 24/27 mm open end spanner, a T20 and T30/T45 torx screw wrench and a towing coupling with pintle pin.
- CO2 calculation is possible in TOPEC RTS.

### **CUSTOMER NEEDS**

#### **DAF THIRD PARTY WORK**

- **Zabudowa kurtynowa 2600/2480/7300 18EP + winda DHOLANDIA 1500 kg**

Nadwozie skrzyniowe z konstrukcją stalową typu kurtyna

- details cut with the use of a laser and formed with the help of folding machines with optical bending angle measurement what guarantees very high accuracy and quality of products,
- the load bearing elements of box bodies due to the folding machine with the 11-metre working area are prepared in one section,
- all the elements are made of steel of improved mechanical resistance, sand-blasted, zinc-plated and then varnished,
- the structures of box bodies are welded with the use of welding robots,
- floor lined with waterproof anti-slippery plywood with the thickness and resistance which depends on the vehicle load capacity,
- handles on the circumference which do not allow for the cargo to move during the transportation,
- front wall made from aluminium,
- steel and aluminium framework, lined with aluminium boards which protect the tarpaulin from damage, the framework steel elements are sand-blasted and varnished,
- removable side columns,
- tarpaulin made of German production PVC Mehler material,
- side bodywork protected from mechanical damage with buffers made of plastics,
- wheel house shells made of plastics with protective aprons located above the rear axis wheels,

- mudguards equipped in anti-splash mat per regulation 109/2011,
- lateral aluminium covers pursuant to Reg. 73,
- contour labelling and marker lamps pursuant to Reg. 48
- **2 x opening curtain side on two sides without sideboards,**

\*the height of the rear doors of the light is reduced from 30 to 50 mm

**inside dimensions**

- długość wew. 6900 mm

- szer. wewn. 2480 mm

- wys. wewn. 2600 mm mm

**2 x tool box made of plastics locked with a key,**

**LIFT : DHOLLANDIA 1500 kg x 1600 mm**

***FRONT WALL MADE OF ALUMINUM PROFILES TO THE HEIGHT OF THE CABIN***

***ALL THE FRAME CONSTRUCTION INCLUDES ALUMINUM BOARDS***

**OUR CERTIFICATES AND AUTHORIZATIONS THAT GUARANTEE HIGH QUALITY**

- ISO 9001:2015 Quality Management System
- Certificate of Approval
- Certificate of Product Conformity according to PN EN 12642

---

Thank you for your trust and choosing us as your supplier.

